



Empowered by  
**U-LINK**

# TRAFFIC BARRIERS

Range of automatic barriers



Be ahead



## GIOTTO BT A ULTRA 36

### Electromechanical barrier for intensive use

The Giotto Ultra is our entry-level barrier for intensive usage, it is suitable for clear drive through gaps of up to 6m. It is fitted with a 24v DC motor and comes with an extensive range of accessories which makes it suitable for almost any environment. The Giotto Ultra has the same design style as the Maxima Ultra 36 barrier. The Giotto Ultra has a Merak control panel which is U-Link compatible and is equipped with scenario programming for fast and precise installations. It is possible to fully programme the control panel using just a handful of selection options on the display, saving time and ensuring the best results. The control panel is located in the upper part of the barrier and protected by a solid aluminium casing for easy and safe programming and maintenance operations. The barrier is compatible with the P5 boom range.

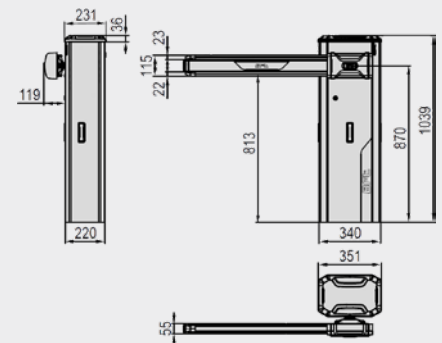
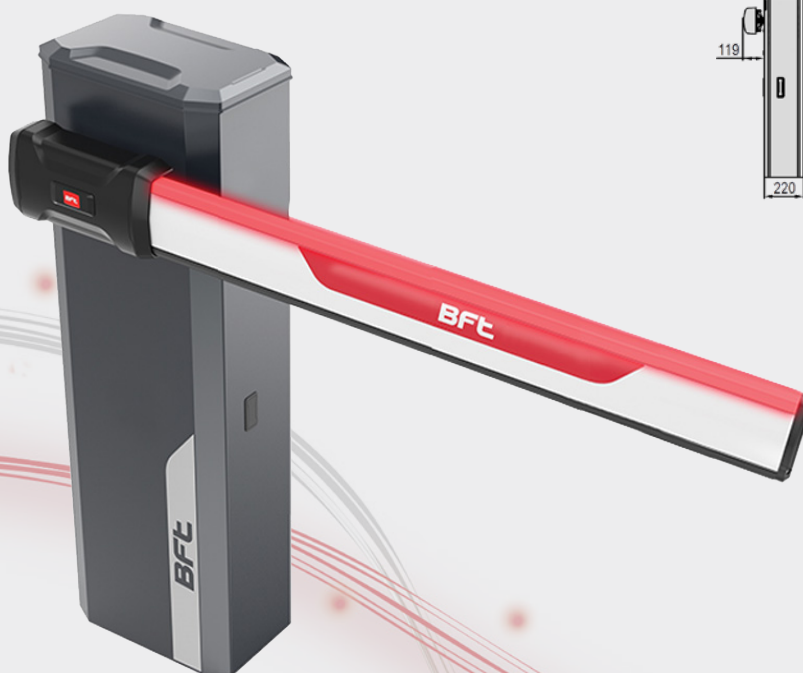

U-Link



Rolling Code



ER Ready



EE Link



24v

### FEATURES

- Encoder technology
- Control unit with U-Link and programming display
- 24v motor

### SPECIFICATIONS

	GIOTTO BT A ULTRA 36	GIOTTO BT A ULTRA 36 XL
Opening	max. 4m	max. 6m
Frequency of use	5,000 movements per day	2,000 movements per day
Opening or closing	2.2 sec (@3m)	4 sec (@6m)
Control unit	MERAK	MERAK
Motor power supply	24v	24v
Gearbox type	grease lubricated	grease lubricated
Limit switch type	electromechanical	electromechanical
Slowdown	adjustable	adjustable
Locking	mechanical	mechanical
Unlocking	personalised key	personalised key
Environmental conditions	-20°C to +55°C	-20°C to +55°C
Protection rating	IP54	IP54



# MICHELANGELO

## Automatic barrier for intensive use

The Michelangelo is our mid-level barrier for intensive usage, it is suitable for clear drive through gaps of up to 8m. The wide range of accessories, option for a built-in flashing light around the cabinet and simple system for installing photocells makes them suitable for virtually any environment.

The control panel is positioned at the top of the cabinet for easy access, it has a programming display, a built-in dual channel radio receiver and is compatible with U-Link. The limit switch system with electronic adjustment can speed-up installation time and provides greater precision of movement. The barrier is available with an optional back-up battery power supply system which can be installed inside the cabinet.

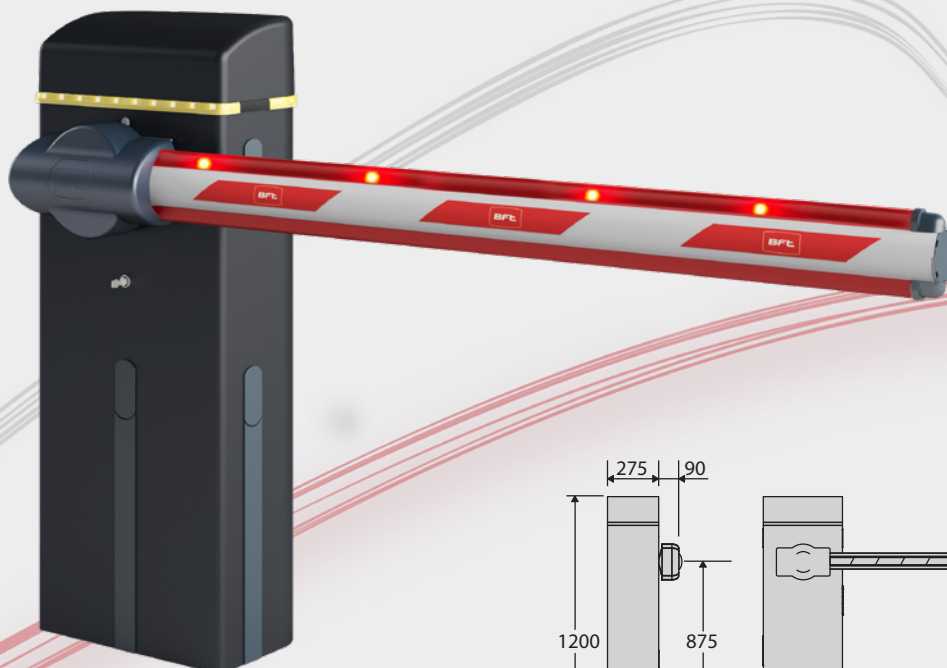

-  U-Link
-  Rolling Code
-  ER Ready
-  EE Link
-  24v
-  Block

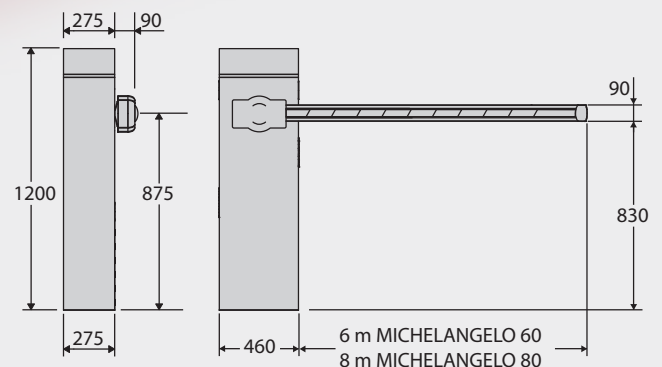

### FEATURES

- Control panel with programming display and compatible with U-Link
- IP54 protection

### SPECIFICATIONS

	MICHELANGELO BT A 60 U	MICHELANGELO BT A 80 U
Useful passage	6m	8m
Control panel	MERAK BM	MERAK BM
Power supply	24v	24v
Opening or closing	6 sec.	8 sec.
Type of limit switch	electronic	electronic
Slowdown	adjustable	adjustable
Lock	mechanical	mechanical
Release	key	key
Frequency of use	intensive	intensive
Ambient conditions	from -20 °C to 50°C (-40 °C with thermo activation)	from -20 °C to 50°C (-40 °C with thermo activation)
Protection rating	IP54	IP54



# MAXIMA ULTRA 36

## Automatic barrier for continuous use

A 230v AC electromechanical barrier equipped with an asynchronous three-phase motor and inverter, designed for very high frequency use. The Maxima Ultra 36 can manage clear drive through gaps from 2m to 6m. It is designed to operate in a wide range of environments such as large car parks, industrial sites and motorway tolls with very heavy traffic levels.

The barrier can be configured to manage the drive through gap using the top mounted control panel. The mechanical crankshaft delivers fluid movement for the boom whilst controlling the soft opening and closing. The same mechanism is able to provide anti-vandalism protection for the gear motor. The barrier is U-Link compatible for integration with Parking Management or Building Management systems.

The LED Light Crown mounted on the top of the cabinet is able to communicate diagnostic information with a multi-colour coded system providing maintenance and other vital information without the need to access the control panel.

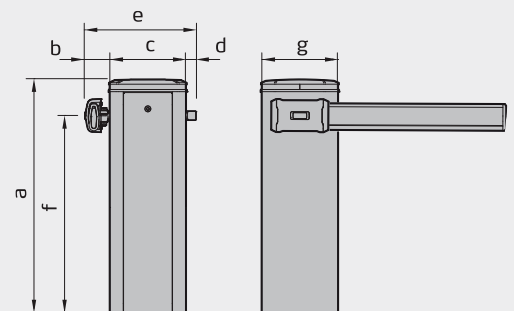
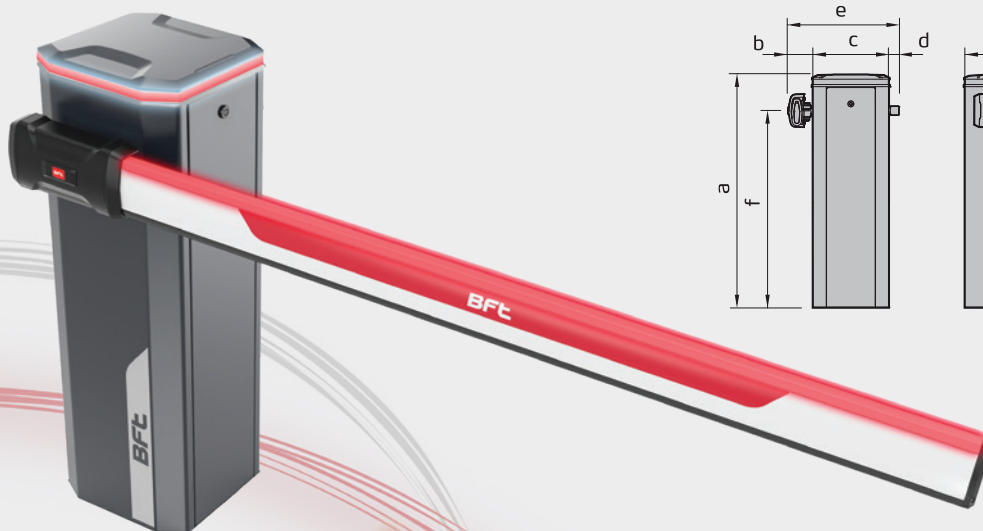

### FEATURES

- Oil bath gear motor
- Manage openings up to 6m
- Self-diagnostics function
- Asynchronous three-phase motor with inverter
- Control panel under the cap and compatible with U-Link
- Three access points for simplified maintenance
- Anti-vandal protection with connecting rod-crank system

### DIMENSIONS

MODEL	A	B	C	D	E	F	G
MAXIMA Ultra 36	1,030	110	338	45	493	870	338

### SPECIFICATIONS

	MAXIMA ULTRA 36
Useful passage	2 m to 6 m
Frequency of use	20,000 (@3 m), 5,000 (@6 m) movements per day
Opening and closing	0.7 - 3.9 seconds
Control panel	CSB XT
Motor type	asynchronous three-phase
Gear unit type	oil bath
MCBF (mean cycles between failures)	7,000,000 movements
Motor power supply	230 V
Slowdown	soft opening and closing
Impact reaction	encoder
Lock	mechanical
Release	inside the structure
Ambient conditions	-40°C to +60°C
Protection rating	IP55



# MAXIMA ULTRA 68

Automatic barrier for very intensive/continuous use

A range of 230v AC electromechanical barriers equipped with a three-phase induction motor and inverter designed for very intensive use. Developed to operate in a wide variety of environments such as large car parks, motorway tolls and industrial sites, the Maxima Ultra 68 is suitable for clear drive through gaps from 4m to 8m.

The mechanical movement with connecting rod-crank mechanism controls the smooth operation of the boom, while managing slowdown in opening and closing. The same mechanism provides anti-vandal protection for the gear motor. The barrier is U-Link compatible which allows the integration of Parking Management or Building Management Systems.

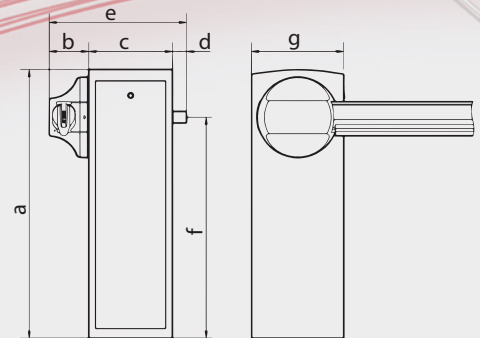
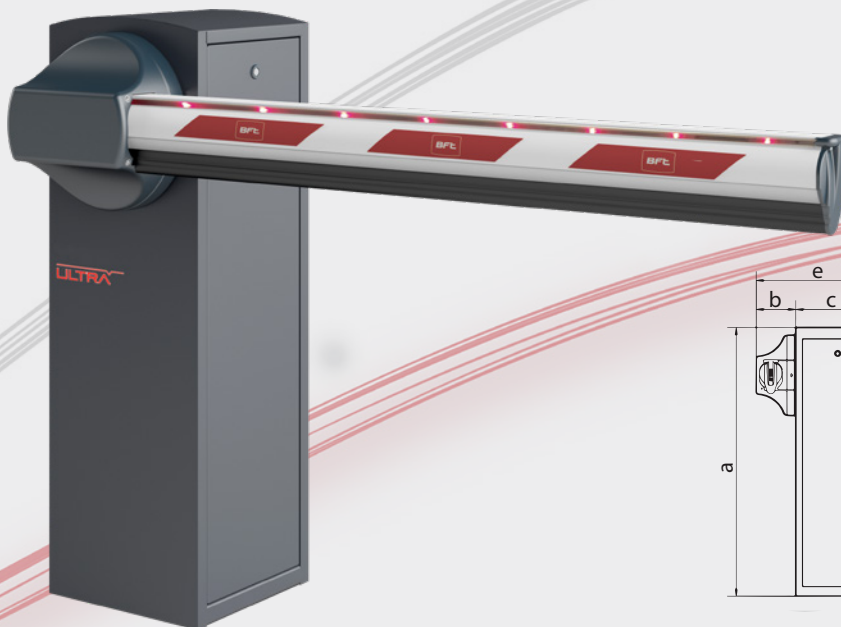

-  U-Link
-  Rolling Code
-  Oil Gear
-  Encoder
-  Inverter
-  Block
-  Tri

## FEATURES

- Three-phase induction motor
- Control panel compatible with U-Link
- Anti-vandal protection with connecting rod-crank system

## DIMENSIONS

MODEL	A	B	C	D	E	F	G
MAXIMA Ultra 68	1155	170	360	60	590	950	400

## SPECIFICATIONS

	MAXIMA ULTRA 68
Useful passage	4m to 8m
Frequency of use	3000 Op/day
Opening or closing	4.5 - 6 sec
Control panel	CSB XT
Motor type	three-phase induction
Gear unit type	in oil bath
MCBF (Mean Cycles Between Failure)	2,000,000 Op
Motor power supply	230v
Slowdown	in opening and closing
Impact reaction	encoder
Lock	mechanical
Release	inside the structure
Ambient conditions	-30°C +60°C
Protection rating	IP54



A BRAND OF **SOMFY** GROUP

#### **UK North Office**

Units C2-C4 The Embankment  
Business Park, Vale Road, Heaton  
Mersey, Stockport, SK4 3GL  
United Kingdom  
T. 0161 456 0456  
[north.uk@bft-automation.com](mailto:north.uk@bft-automation.com)

#### **UK South Office**

Unit 2, Warwick House,  
Edison Park, Swindon, SN3 3RB  
United Kingdom  
T. 01488 674 750  
[south.uk@bft-automation.com](mailto:south.uk@bft-automation.com)

#### **Ireland Office**

Unit D3 City Link Business Park,  
Old Naas Road, Dublin, D12 YHY4  
Ireland  
T. +353 1 456 4711  
[sales.ie@bft-automation.com](mailto:sales.ie@bft-automation.com)